

# Temp/Humidity Transducer

## Model HU-226



- **Ultra-fast response polymer capacitance humidity sensor and precision thermistor or platinum RTD Temperature Sensor**
- **Not affected by condensation, fog, high humidity or contaminants**
- **Highly accurate, repeatable, stable output with negligible hysteresis**
- **Wide 12-40 VDC/12-35 VAC unregulated supply voltage (humidity only)**
- **Two temperature compensated humidity output versions, 4-20 mA 2-wire or field selectable 0-5 VDC/ 0-10 VDC**
- **NIST traceable  $\pm 2\%$  or  $\pm 3\%$  calibration and  $\pm 0.2\%^\circ\text{C}$  thermistor interchangeability or  $\pm 0.1\%$  RTD accuracy**
- **Enclosure type NEMA 4 (IP-65) duct mount**
- **Conforms to EMC standards EN50082-1/ EN55014/EN60730-1**

The HU-226 is an extremely fast, stable and accurate Temp/Humidity Transducer designed for harsh environments. The polymer humidity capacitance sensor is not affected by harsh contaminants, condensation, fog or extremely high humidity over a prolonged period of time. If dust or other contaminants accumulate on the sensor, the probe can be washed in industrial grade isopropyl alcohol and put back in service without any calibration shift. Each unit is individually calibrated in an environmental test chamber to meet or exceed NIST traceable  $\pm 2\%$  or  $\pm 3\%$  accuracies. The HU-226 is temperature compensated for  $-30^\circ\text{F}$  to  $+130^\circ\text{F}$  operation with negligible error. Field selectable outputs, and fully temperature compensated NIST traceable accuracy, non-interacting zero and span adjustments, NEMA 4 (IP-65) steel enclosure with external mounting bracket, short circuit and reverse polarity protected output, and a liberal two year warranty are some of the features which make the HU-226 the industry's highest performance, most reliable Temp/Humidity Transducer.

DISTRIBUTED BY:



CONTROL SERVICE, INC.

P.O. Box 250

P: 847.356.0566

GRAYSLAKE, IL 60030

F: 847.356.0747

DN226.1

Printed in USA

[WWW.MMCONTROL.COM](http://WWW.MMCONTROL.COM)

## HU-226

The HU-226 incorporates a bulk polymer capacitive humidity sensor and precision NTC thermistor/platinum RTD temperature sensor. Both Temperature and Humidity Sensors are immune to most contaminants and at the same time provide a stable, repeatable, accurate humidity and temperature measurement with negligible hysteresis. The sensing elements are not affected by condensation. In fact, the probe may be immersed in distilled water without degrading the calibration accuracy. The HU-226 utilizes sophisticated integrated circuits to provide a high level, fully conditioned, and temperature compensated humidity output. The thermistor temperature sensors are available with more than ten different industry standard resistance to temperature curves offering compatibility to most if not all control systems. All thermistor sensors offer  $\pm 0.2^{\circ}\text{C}$  interchangeability/accuracy. All thermistors strictly conform to industry standard R/T curves. The platinum RTD's are available with 100 ohm or 1000 ohm din 437630 standards with glass beaker  $\pm 0.12\%$  accuracy at  $0^{\circ}\text{C}$ . All temperature sensors have more than  $3.0 \text{ mW} / ^{\circ}\text{C}$  heat dissipation constant.

On VDC output units (humidity only), two additional field selectable options are available; dual outputs 0-5 or 0-10 VDC, and dual unregulated supply voltages 12-35 VAC or 12-40 VDC. By merely moving a shorting plug, one can select the desired output for the specific application. As far as supply voltage is concerned, the unit automatically configures for AC or DC and no field selection is necessary. Another feature is that the output is fully protected from short circuit to ground, or if the supply voltage is applied by mistake to the output. Past experience demonstrates that field related wiring problems do occur. Instead of denying this fact, this protection circuit is designed in to ensure trouble-free start-up. The VDC output unit is also designed to handle low impedance circuits. In fact, the unit can drive up to 1K ohm minimum. In this way, multiple controllers, indicators, or other devices can be paralleled to the output without performance degradation.

The mA output units (humidity only) function over a wide unregulated supply voltage range: 12-40 VDC without any effect on calibration or performance. The unit has reverse polarity protection built in. As a result, it is next to impossible to damage the unit by wiring incorrectly.

By using sophisticated low dropout voltage regulators and CMOS integrated circuits, the mA output unit can drive very high output impedance. In fact, with only 12 VDC supply, the unit can drive 400 ohms. At 40 VDC, the unit is capable of handling up to a 3000 ohm load. In this way, the output loop can be tied in series to multiple controllers, indicators, and other devices without degrading the performance.

NIST traceable humidity standards are utilized to calibrate and certify the HU-226. Calibration data on each unit is archived digitally for SPC and QC purposes. All automated calibration systems are networked and data is available on line to numerous individuals at the same time. In this way, extremely high standards of quality and calibration integrity are maintained.

The HU-226 incorporates a rugged NEMA 4 (IP-65) fully gasketed, dust proof and splash proof enclosure. The enclosure has an external mounting bracket to facilitate field installation. A  $1/2"$  (.875" / 22.25 mm diameter) knock-out for conduit connection is also provided. A liquid tight cable connector is supplied if the unit is not being hard wired. Once installed, the enclosure maintains its environmental rating and protects the electronics and the sensing element from condensation, corrosive contaminant's and other environmental pollutants. The enclosure also has additional features for ease of installation including unplugable terminal block, easily accessible zero and span trimmers, and conveniently located shorting plugs for field selection.

# HU-226

## HUMIDITY TRANSDUCER

### SPECIFICATIONS:

**Accuracy\*:**  $\pm 2\%$  /  $\pm 3\%$  RH

**Range:** 0-100% RH

**Hysteresis:**  $\pm 1\%$

**Supply voltage:** 12-40 VDC 12-35 VAC  
(VDC output units only)

**Compensated Temp Range:** -30°F-130°F  
(-35°C-55°C)

**Load Impedance:** 3000 ohms max. at 40 VDC  
(mA output unit 1000 ohms min. (VDC output unit))

## TEMPERATURE SENSOR

### SPECIFICATIONS:

**Interchangeability:**  $\pm 0.2^\circ\text{C}$

**Heat Dissipation:** 3.0 mW/°C

**R/T Characteristics:** See TI. SN01-01

**Operating Temp.:** -30°F to 130°F (-35°C to 55°C)

**Conformance:** EMC Standards EN50082-1 (1992)  
EN55014 (1993)/EN60730-1 (1992)

\* Includes non-linearity and non-repeatability

## PLATINUM RTD SENSOR

### SPECIFICATIONS:

**Accuracy:** 0.12% at 0°C

**Resistance:** 100 or 1000 ohm at 0°C

**Standard:** Din 43760

**Operating Temp. Range:** -30°F to 130°F (-35°C to 55°C)

**Heat Dissipation:** 3.0 mW/°C

**Technology:** Thin film deposition laser trimmed (LPVD)

**Conformance:** EMC Standards EN50082-1 (1992)  
EN55014 (1993)/EN60730-1 (1992)

### GENERAL SPECIFICATIONS:

**Environmental:** 10-90% RH Non-Condensing

**Enclosure:** 18 Ga C.R. Steel NEMA 4 (IP-65)

**Finish:** Baked on enamel -PMS2GR88B

**Termination:** Unpluggable screw terminal block

**Wire Size:** 12 Ga maximum

**Weight:** Duct mount 1.0 lbs. (.45 kg)

## ORDERING INFORMATION: HU-226-

ACCURACY	OUTPUT	TEMP SENSOR
$\pm 2\%$	<b>mA</b> (4-20 mA 2-wire)	<b>3</b> 1,000 ohm Platinum R/T Table#3
$\pm 3\%$	<b>VDC</b> (0-5 or 0-10 VDC field selectable)	<b>5</b> 1000 ohm Balco Table #5
		<b>7</b> 10,000 ohm Thermistor at 25°C R/T Table #7
		<b>7Z<sup>‡</sup></b> 10,000 ohm Thermistor at 25°C Table #7Z
		<b>10</b> 3,000 ohm Thermistor at 25°C Table #10
		<b>12</b> 10,000 ohm Thermistor at 25°C Table #12
		<b>17</b> 20,000 ohm Thermistor at 25°C Table #17

<sup>‡</sup> with 11k OHM resistor in parallel

**Example:** HU-226-2-mA-3: Temperature/Humidity Transducer,  $\pm 2\%$  RH accuracy with 4-20 mA output. See Table 3, 1000 ohm Platinum R/T Temperature Sensor.

# HU-226

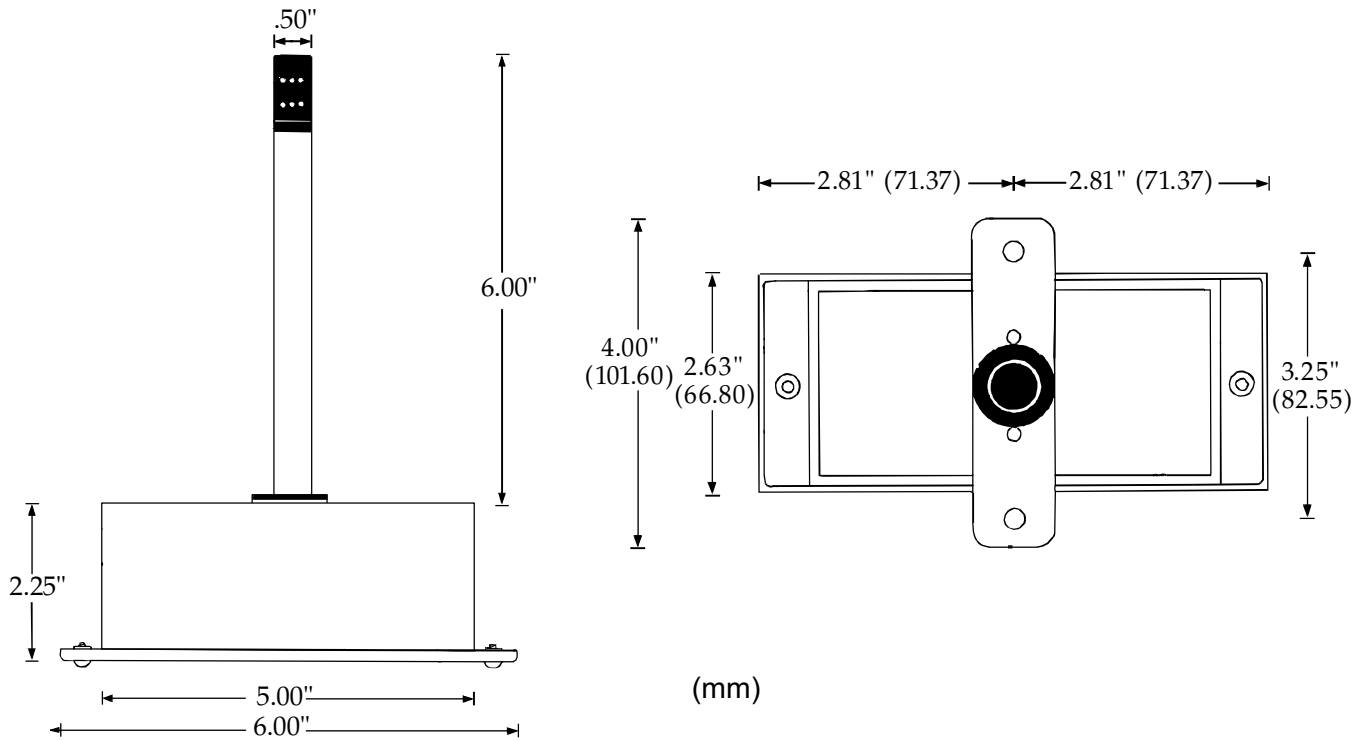

(mm)

**WARRANTY:** MAMAC Systems, Inc. warrants its products to be free of defects in material and workmanship for a period of two (2) years from date of shipment. If a unit is malfunctioning, it must be returned to the factory for evaluation. A return authorization number (RMA) will be issued by the customer service department and this number must be written or prominently displayed on the shipping boxes and all related documents. The defective part should be shipped freight prepaid to the factory. Upon examination by MAMAC Systems, Inc., if the unit is found to be defective, it will be repaired or replaced at no charge to the customer. However, this warranty is void if the unit shows evidence of being tampered with, damaged during installation, misapplied, misused, or used in any other operating condition outside of the units published specifications.

**MAMAC Systems, Inc. makes no other warranties or representations of any kind whatsoever, expressed or implied, except that of title. All implied warranties including any warranty of merchantability and fitness for a particular purpose are hereby disclaimed. User is responsible to determine suitability for intended use.**

**LIMITATIONS OF LIABILITY:** The remedies of buyer set forth herein are exclusive and the total liability of MAMAC Systems, Inc. with respect to this order, whether based on contract, warranty, negligence, indemnification, strict liability or otherwise, shall not exceed the purchase price of the product upon which liability is based. **In no event shall MAMAC Systems, Inc. be liable for consequential, incidental or special damages.** MAMAC Systems, Inc. reserves the right to change any specifications without notice to improve performance, reliability, or function of our products.

Every precaution for accuracy has been taken in the preparation of this manual, however, MAMAC Systems, Inc. neither assumes responsibility for any omissions or errors that may appear nor assumes liability for any damages that result from the use of the product in accordance with the information contained in the manual.

DISTRIBUTED BY:



**CONTROL SERVICE, INC.**

P.O. Box 250

P: 847.356.0566

GRAYSLAKE, IL 60030

F: 847.356.0747