

Humidity Transducer

Model HU-224/225



- Ultra-fast response polymer capacitance sensor
- Not affected by condensation, fog, high humidity or contaminants
- Highly accurate, repeatable, stable output with negligible hysteresis
- Wide 12-40 VDC/12-35 VAC unregulated supply voltage
- Two temperature compensated output versions, 4-20 mA 2-wire or field selectable 0-5 VDC/0-10 VDC
- Non-interacting zero and span trimmers
- NIST traceable $\pm 2\%$ or $\pm 3\%$ calibration
- Two enclosure types NEMA 4 (IP-65) duct mount or aesthetically appealing ABS plastic wall mount
- Short circuit and reverse polarity protected
- Conforms to EMC standards EN50082-1/EN55014/EN60730-1

The HU-224/225 is an extremely fast, stable and accurate humidity transducer designed for harsh environments. The polymer capacitance sensor is not affected by harsh contaminants, condensation, fog or extremely high humidity over a prolonged period of time. If dust or other contaminants accumulate on the sensor, the probe can be washed in industrial grade isopropyl alcohol and put back in service without any calibration shift. Each unit is individually calibrated in an environmental test chamber to meet or exceed NIST traceable $\pm 2\%$ or $\pm 3\%$ accuracies. The HU-224/225 is temperature compensated for -30°F to -130°F operation with negligible error. For space humidity, an aesthetically appealing ABS enclosure which may be flush mounted or fits a standard 2" x 4" handy box is available and for duct humidity applications, a rugged NEMA 4 (IP-65) steel enclosure with external mounting bracket is also available. Two enclosure types, field selectable outputs, fully temperature compensated NIST traceable accuracy, non-interacting zero and span adjustments, short circuit and reverse polarity protected output, and a liberal two year warranty are some of the features which make the HU-224/225 the industry's highest performance, most reliable humidity transducer.

DISTRIBUTED BY:



CONTROL SERVICE, INC.

P.O. Box 250

P: 847.356.0566

GRAYSLAKE, IL 60030

F: 847.356.0747

WWW.MMCONTROL.COM

HU-224/225

The HU-224/225 incorporates a bulk polymer capacitive ultra-fast sensing element which is immune to most contaminants and at the same time provides a stable, repeatable, and accurate humidity measurement with negligible hysteresis. The sensing element is not affected by condensation. In fact, it may be immersed in distilled water without degrading the calibration accuracy. The HU-224/225 utilizes sophisticated integrated circuits to provide a high level, fully conditioned, and temperature compensated output.

On VDC output units, two additional field selectable options are available; dual outputs 0-5 or 0-10 VDC, and dual unregulated supply voltages 12-35 VAC or 12-40 VDC. By merely moving a shorting plug, one can select the desired output for the specific application. As far as supply voltage is concerned, the unit automatically configures for AC or DC and no field selection is necessary. Another feature is that the output is fully protected from short circuit to ground, or if the supply voltage is applied by mistake to the output. Past experience demonstrates that field related wiring problems do occur. Instead of denying this fact, this protection circuit is designed in to ensure trouble-free start-up. The VDC output unit is also designed to handle low impedance circuits. In fact, the unit can drive up to 1k ohm minimum. In this way, multiple controllers, indicators, or other devices can be paralleled to the output without performance degradation.

The mA output units can function over a wide unregulated supply voltage range: 12-40 VDC without any effect on calibration or performance. The unit has reverse polarity protection built in. As a result, it is next to impossible to damage the unit by mis-wiring. By using sophisticated low drop-out voltage regulators and CMOS integrated circuits, the

mA output unit can drive very high output impedance. In fact, with only 12 VDC supply, the unit can drive 400 ohms. At 40 VDC, the unit is capable of handling up to 3000 ohms load. In this way, the output loop can be tied in series to multiple controllers, indicators, and other devices without degrading the performance.

NIST traceable humidity standards are utilized to calibrate and certify the HU-224/225. Calibration data on each unit is archived digitally for SPC and QC purposes. All automated calibration systems are networked and data is available on-line to numerous individuals at the same time. In this way, extremely high standards of quality and calibration integrity are maintained.

The HU-224/225 incorporates a rugged NEMA 4 (IP-65) fully gasketed, dust proof and splash proof enclosure for monitoring duct humidity or an aesthetically appealing ABS plastic wall mount enclosure for monitoring space humidity. The enclosure has an external mounting bracket to facilitate field installation. A 1/2" (.875"/22.25mm dia.) knock-out for conduit connection is also provided. A liquid tight cable connector is also supplied if the unit is not being hard wired. Once installed, the enclosure maintains its environmental rating and protects the electronics and the sensing element from condensation, corrosive contaminants and other environmental pollutants. The wall mount enclosure may be flush mounted on any flat surface or fits a standard 2" x 4" handy box. Louvers are provided on the top and bottom of the enclosure to ensure ample air flow for fast response. Both enclosure options also have additional features for ease of installation including unpluggable terminal block, easily accessible zero and span trimmers, and conveniently located shorting plugs for field selection.

HU-224/225

SPECIFICATIONS:

Accuracy*: $\pm 2\%$ / $\pm 3\%$ RH

Range: 0-100% RH

Hysteresis: $\pm 1\%$

Supply Voltage: 12-40 VDC
12-35 VAC (VDC output units only)

Supply Current: VDC Units - 10 mA max.
mA Units - 20 mA max.

Enclosure: 18 Ga C. R. Steel NEMA 4 (IP-65)
or ABS Plastic

Finish: Baked on enamel-PMS2GR88B
or off-white

Conformance: EMC Standards EN50082-1(1992)
EN55014(1993)/EN60730-1(1992)

Compensated Temp Range: -30°F-130°F (-35°C-55°C)

Environmental: 10-90%RH Non-Condensing

Termination: Unpluggable screw terminal block

Wire Size: 12 Ga max.

Load Impedance: 3K ohms max. at 40 VDC (mA
output units) 1K ohms min. (VDC output units)

Weight: Duct mount: 1.0 lbs. (.45 kg)
Wall mount: 0.5 lbs. (.25 kg)

**Includes non-linearity and non-repeatability*

Ordering Information: HU-

PACKAGING	ACCURACY	OUTPUT
224 (duct mount)	$\pm 2\%$	mA (4-20 mA 2-wire)
225 (wall mount)	$\pm 3\%$	VDC (0-5 VDC or 0-10 VDC field selectable)

Example: HU-224-2-mA: Duct Humidity Transducer $\pm 2\%$ RH accuracy with 4-20 mA output.

CAUTION: Do not use in explosive/hazardous environments or with flammable/combustible media.

HU-224/225

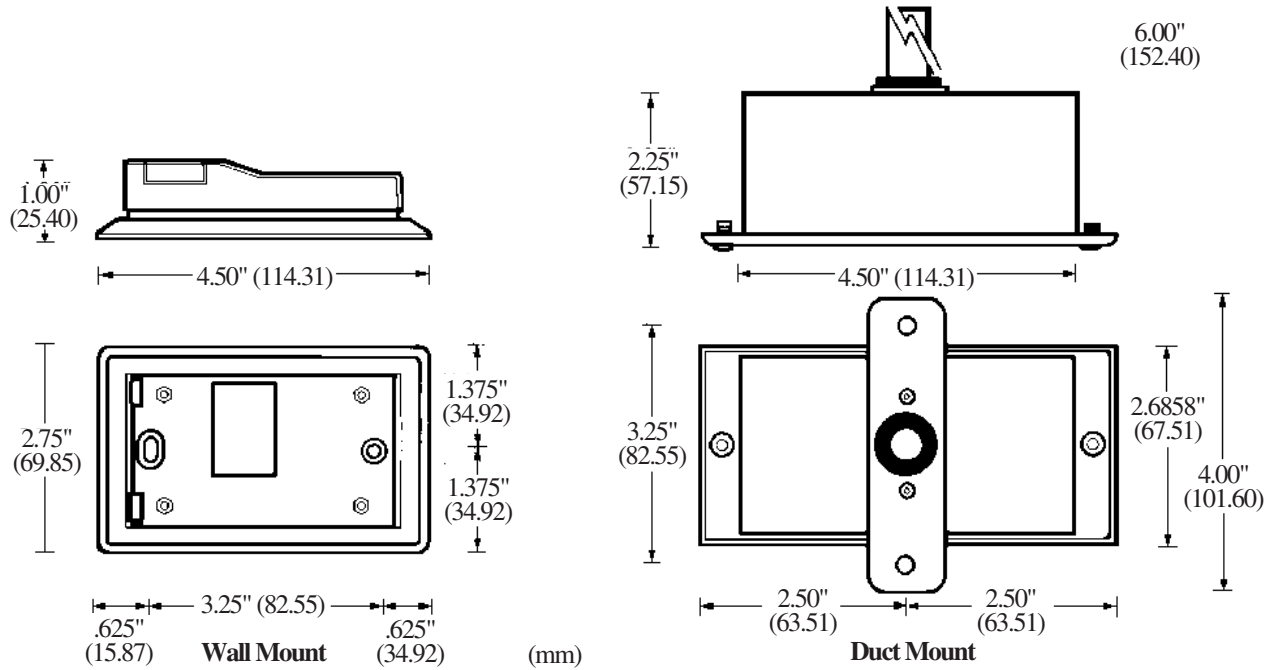

WARRANTY: MAMAC Systems, Inc. warrants its products to be free of defects in material and workmanship for a period of two (2) years from date of shipment. If a unit is malfunctioning, it must be returned to the factory for evaluation. A return authorization number (RMA) will be issued by the customer service department and this number must be written or prominently displayed on the shipping boxes and all related documents. The defective part should be shipped freight pre-paid to the factory. Upon examination by MAMAC Systems, Inc., if the unit is found to be defective, it will be repaired or replaced at no charge to the customer. However, this warranty is void if the unit shows evidence of being tampered with, damaged during installation, misapplied, misused, or used in any other operating condition outside of the unit's published specifications.

MAMAC Systems, Inc. makes no other warranties or representations of any kind whatsoever, expressed or implied, except that of title. All implied warranties including any warranty of merchantability and fitness for a particular purpose are hereby disclaimed. User is responsible to determine suitability for intended use.

LIMITATIONS OF LIABILITY: The remedies of buyer set forth herein are exclusive and the total liability of MAMAC Systems, Inc. with respect to this order, whether based on contract, warranty, negligence, indemnification, strict liability or otherwise, shall not exceed the purchase price of the product upon which liability is based. **In no event shall MAMAC Systems, Inc. be liable for consequential, incidental or special damages.** MAMAC Systems, Inc. reserves the right to change any specifications without notice to improve performance, reliability, or function of our products.

Every precaution for accuracy has been taken in the preparation of this manual, however, MAMAC Systems, Inc. neither assumes responsibility for any omissions or errors that may appear nor assumes liability for any damages that result from the use of the product in accordance with the information contained in the manual.

DISTRIBUTED BY:



CONTROL SERVICE, INC.

P.O. Box 250

P: 847.356.0566

GRAYSLAKE, IL 60030

F: 847.356.0747

WWW.MMCONTROL.COM