

CHEM-FEED[®]

INJECTOR

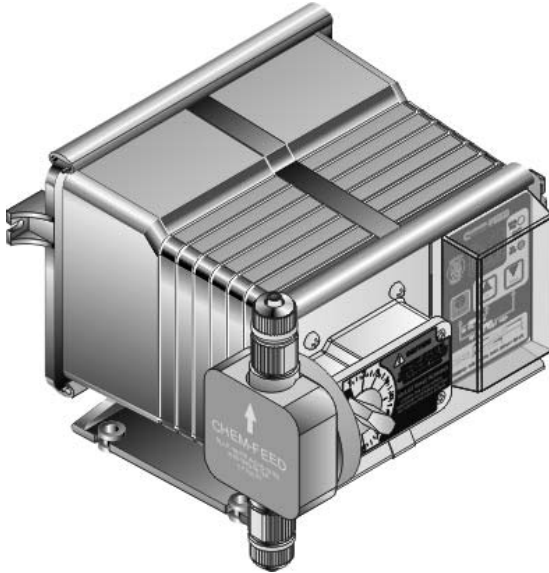

MODEL C-1100 MODEL-V

VARIABLE SPEED

POSITIVE DISPLACEMENT INJECTOR PUMP

OPERATING MANUAL

Blue-White[®]
Industries, Ltd.

TABLE OF CONTENTS

1.....Introduction	3
2.....Specifications.....	3
3.....Features.....	3
4.....Unpacking.....	3
5.....Installation	4
5.1..Mounting location.....	4
5.2..Input power connections	5
5.3..External input signal connections.....	6
5.4..How to install the tubing and fittings.....	8
6.....How to operate the Pump	10
6.1..Description of pump output adjustment controls.....	10
6.2..How to adjust the output - manual stroke adjustment	11
6.3..Mode 1 - Manually Adjusting the output.....	11
6.4..Mode 2 - 4-20 mA input.....	12
6.5..Mode 3 - 0-10 VDC input	14
6.6..Mode 4 - Frequency (Hz) input	16
6.7..Measuring the pump output - Volumetric test	18
6.8..FVS Flow Verification System	18
7.....How to maintain the Pump.....	20
7.1..Routine inspection and cleaning.....	20
7.2..How to clean the pump	20
7.3..500 hour service warning timer.....	20
Pump head and Valve exploded view drawing	21
Replacement parts drawing	22
Replacement parts list	23
Warranty information.....	24
Authorized service centers	25

C-1100V

1.0 Introduction

Congratulations on purchasing the C-1100 Model-V Variable speed positive displacement metering pump. The C-1100 is designed to inject chemicals into piping systems and is capable of injecting against a high system pressure up to 150 PSI (10.4 bar). In addition to the front mounted mechanical flow rate adjustment, the C-1100 Model-V unit is equipped with an external input control circuitry which allows the pumps output to be externally controlled by either a 4-20mA input signal, a 0-10V DC input signal or a pulsed input signal.

2.0 Specifications

Maximum Working Pressure	150 psig / 10.4 bar (most models)
Maximum Fluid Temperature	130° F / 54° C
Ambient Temperature Range	14 to 110° F / -10 to 43° C
Duty Cycle	Continuous
Adjustment Range	5-100% of speed
Maximum Viscosity	1,000 Centipoise
Maximum Suction Lift	up to 30 ft. water
Power Requirements	108/130Vac 60Hz 40 Watts, 208/250Vac 40Hz 40 Watts, 208/250Vac 60Hz 45 Watts
Dimensions	6-1/8" H x 10-1/8" W x 9" D
Weight	12 lb.

3.0 Features

- Double-ball, springless ceramic check valves with PVDF (Kynar) body, TFE/P (Aflas) and Viton o-ring seals.
- Easy access, front mounted mechanical feed rate adjustment.
- High outlet pressure capability of 150 psig (most models).
- 400:1 adjustment turn down ratio(speed and stroke combined).
- Digital electronic feed rate control.
- Corrosion proof Valox housing.
- Tamper resistant electronic control panel cover.

4.0 Unpacking

Your pump package should contain the following:

- 1 - Injector pump
- 1 - suction tube footvalve & strainer assembly
- 1 - ceramic tubing weight
- 1 - 5' Length of clear PVC suction tubing
- 1 - 5' Length of opaque LLDPE discharge tubing
- 1 - Injection fitting with internal back-flow check valve
- 1 - Mounting hardware kit

5.0 Installation

CAUTION: Proper eye and skin protection must be worn when installing and servicing the pump.

Note: All diagrams are strictly for guideline purposes only. Always consult an expert before installing the pump into specialized systems. The pump should be serviced by qualified persons only.

5.1 Mounting Location

Choose an area located near the chemical supply tank, chemical injection point and electrical supply. Although the pump is designed to withstand outdoor conditions, a cool, dry, well ventilated location is recommended. Install the pump where it can be easily serviced.

- Mount the pump to a secure surface or wall using the enclosed hardware. Wall mount to a solid surface only. Mounting to drywall with anchors is not recommended.
- Mount the pump close to the injection point. Keep the inlet (suction) and outlet (discharge) tubing as short as possible. Longer discharge tubing increases the back pressure at the pump tube.
- Your solution tank should be sturdy. Keep the tank covered to reduce fumes. Do not mount the pump directly over your tank. Chemical fumes may damage the unit. Mount the pump off to the side or at a lower level than the chemical container.
- Mounting the pump lower than the chemical container will gravity feed the chemical into the pump. This “flooded suction” installation will aid in priming the pump and will reduce output error due to increased suction lift. We recommended installing a shut-off valve, pinch clamp or other means to halt the gravity feed to the pump during servicing.
- Be sure your installation does not constitute a cross connection with the drinking water supply. Check your local plumbing codes.

INJECTOR MOUNTING

Floor Mount

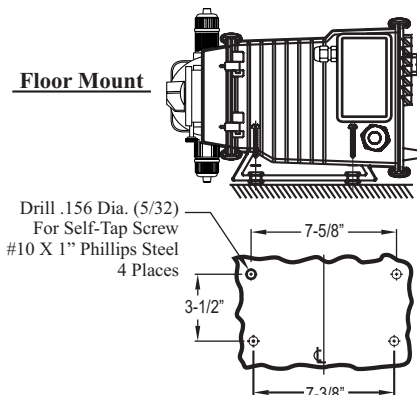

Wall Mount

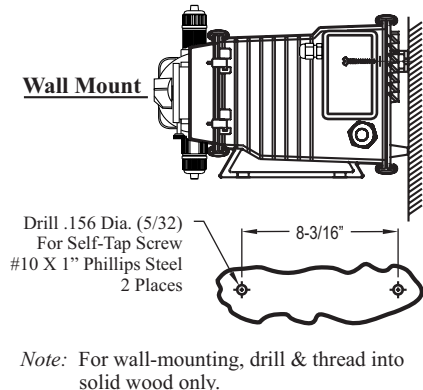

C-1100V

TYPICAL INSTALLATION

Injection / Check valve with 1/4" and 1/2" male pipe threads.
Mount in upward position to prevent trapped gasses in the injection fitting.

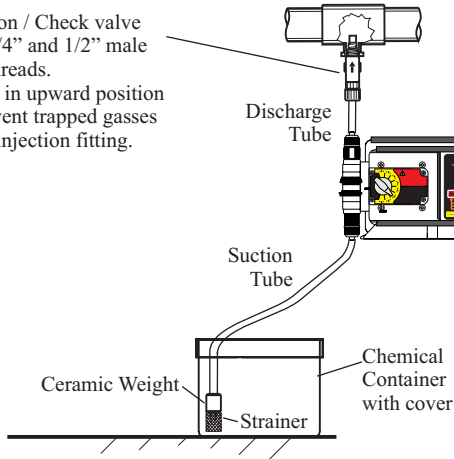

CHEM-FEED®

Wall or shelf mount away from the top of the solution tank. Chemical fumes can damage the unit.

PARTS LOCATOR DRAWING

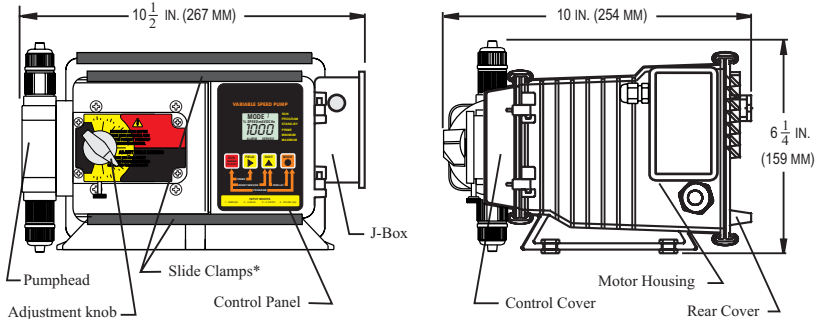

5.2 Input Power Connections

WARNING: Risk of electric shock.

- Be certain to connect the pump to the proper supply voltage. Using the incorrect voltage will damage the pump and may result in injury. The voltage requirement is printed on the pump serial label.
- Removable resistors on the circuit board are factory preset for the correct voltage. See page 7 Circuit Board Connections diagram for details.
- The pump is supplied with a ground wire conductor and a grounding type attachment plug (power cord). To reduce the risk of electric shock, be certain that the power cord is connected only to a properly grounded, grounding type receptacle.

Note: When in doubt regarding your electrical installation, contact a licensed electrician.

5.3 External Input Signal Connections

The C-1100V will accept any one of three different types of external input signals; 4-20 mA , 0-10 VDC, or frequency. The 4-20mA and 0-10 VDC loops must be powered. Two types of frequency inputs, AC sine waves (magnetic coils type outputs) and Digital Square waves (Hall Effect signals, contact closures), are acceptable. A jumper plug located on the circuit board is factory pre-set for AC sine wave signals, the jumper must be re-positioned when digital square wave signals are being used. See page 7, “Hz input jumper settings”

All wiring connections are to be made inside of the junction box located on the side of the C-1100V. A liquid-tite connector is supplied and should be used for the external signal cable. The signal input wires are color coded to the type of signal being used.

SIGNAL INPUT/OUTPUT WIRE COLOR CODES

INPUT TYPE	WIRE COLOR CODE
4-20 mA	BLUE (+) (non-powered) & BLACK (-)
0-10 VDC	ORANGE (+) (non-powered) & BLACK (-)
AC sine wave, TTL, CMOS	WHITE (+) & BLACK (-)
CONTACT (10v @ 2 mA max) HALL EFFECT, NPN	RED (+) & WHITE (-)
ALARM RELAY connect 2-conductor plug to either normally open (NO) (factory default) or normally closed (NC) side of receptacle. 1 AMP MAX @ 125VAC (24VDC)	PURPLE & PURPLE
FLOW VERIFICATION SENSOR	RED/WHITE (+ 20VDC) BLACK (-) YELLOW (signal)
MOTOR ON SIGNAL 5-20V DC open collector output closed while motor is energized	BROWN (+) & BLACK (-)

PADDLEWHEEL SENSOR SIGNAL INPUT WIRING

BLUE-WHITE PADDLEWHEEL SENSOR TYPE	PADDLEWHEEL SENSOR WIRE COLOR CODE	PUMP INPUT WIRE COLOR CODE
MODEL FH HALL EFFECT SENSOR	RED (+) BLACK (-) BARE (signal)	RED (+ 20VDC) BLACK (-) WHITE (signal)
MODEL FC AC SINE WAVE SENSOR	RED (+) BLACK (-)	WHITE (+) BLACK (-)

C-1100V

CIRCUIT BOARD CONNECTIONS

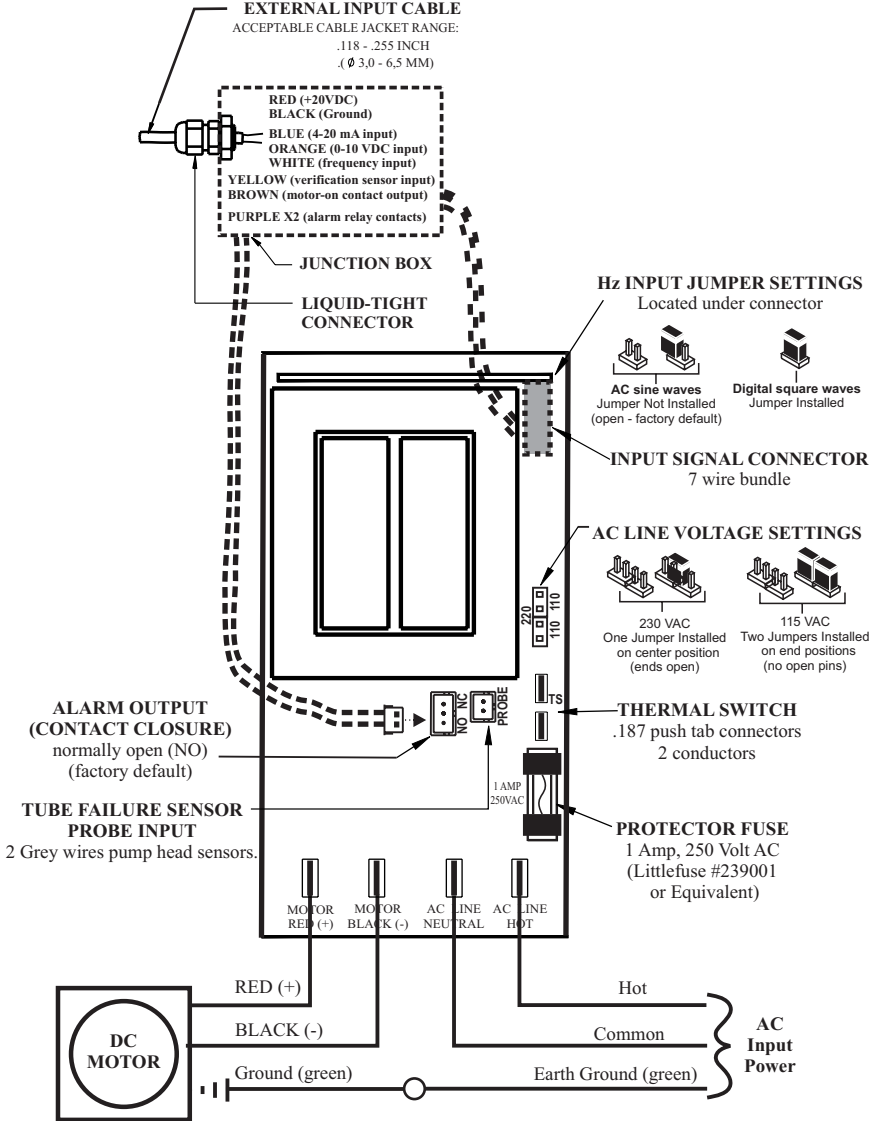

5.4 How To Install the Tubing and Fittings

CAUTION: Proper eye and skin protection must be worn when installing and servicing the pump.

- **Inlet Tubing** - Locate the inlet fitting of the pump head. Remove the tube nut. Push the clear suction tubing through the tube nut and onto the fitting barb. Hand tighten the tube nut to secure the tubing.
- **Footvalve/Strainer** - Trim the inlet end of the suction tubing so that the strainer will rest approximately two inches from the bottom of the solution tank. This will prevent sediment from clogging the strainer. Slip the ceramic weight over the end of the suction tube. Press the strainer's barbed fitting into the end of the tube. Secure the ceramic weight to the strainer. Drop the strainer into the solution tank.
- **Outlet Tubing** - Locate the outlet fitting of the pump head. Remove the tube nut. Push the opaque discharge tubing through the tube nut and onto the compression barb of the fitting. Hand tighten the tube nut to secure the tubing.

Keep outlet tube as short as possible.

- **Injection/Check Valve Fitting Installation** - The Injection/Check valve fitting is designed to install directly into either 1/4" or 1/2" female pipe threads. This fitting will require periodic cleaning, especially when injecting fluids that calcify such as sodium hypochlorite. See section 7.0. Install the Injection/Check valve directly into the piping system. **To prevent trapped gasses, install the fitting in an upward direction.** Use Teflon thread sealing tape on the pipe threads. Push the opaque outlet (discharge) tubing through the tube nut and onto the compression barb of the Injection/Check valve fitting. Hand tighten the tube nut to secure the tubing.

FOOTVALVE/STRAINER

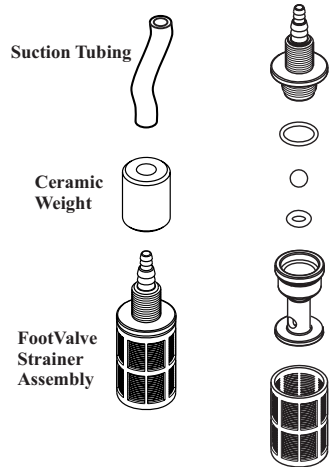

INJECTION/CHECK VALVE

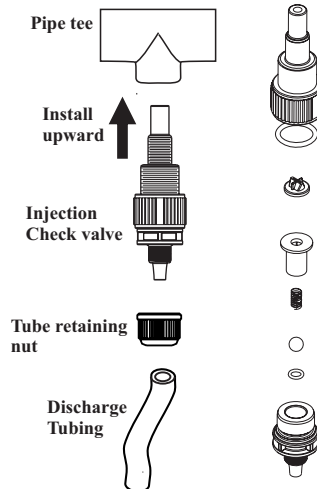

C-1100V

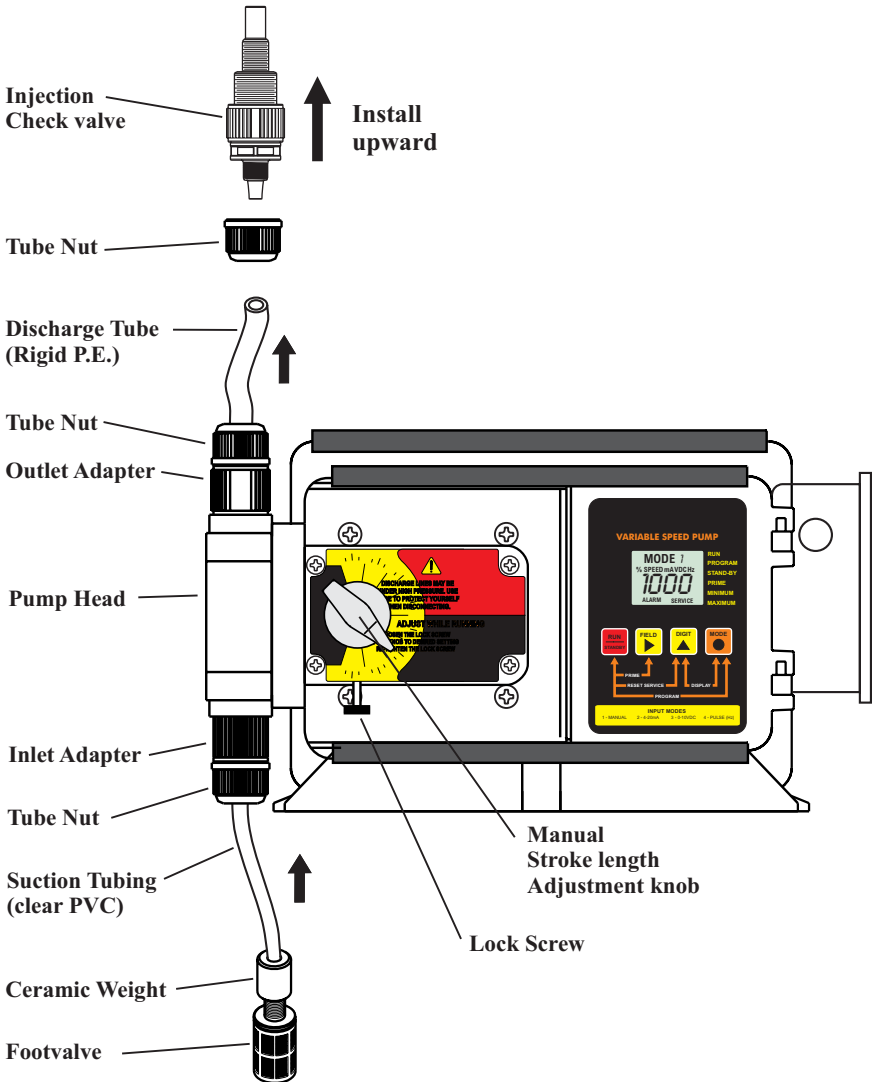

6.0 How To Operate The C-1100V

6.1 Description of Pump Output

Adjustment Controls - Open the control panel door by sliding the upper and lower slide clamps to the left.

- **RUN/STANDBY** Button -

- ❖ Press to start and stop the pump. The **ARROW** next to the word **RUN** will light when in the run mode. The **ARROW** next to the word **STAND-BY** will blink when in the stand-by mode.

- ❖ Press to clear **ALARM**.

- ❖ When pressed with the FIELD Button, initiates a 99 second prime cycle which temporarily overrides the mode setting and runs the pump motor at 100% speed. The **ARROW** next to the word **PRIME** will blink.

- ❖ When pressed with the DIGIT button, resets the 500 hour service warning timer to zero.

- ❖ When pressed with the MODE button, initiates the programming mode. The **ARROW** next to the word **PROGRAM** will blink.

- **FIELD** Button -

- ❖ In the programming mode, selects the digit to be changed.

- ❖ When pressed with the DIGIT button, initiates the Flow Verification Sensor feature and allows programming the alarm delay from 1-256 seconds.

- **DIGIT** Button -

- ❖ In the programming mode, increases the selected digit.

- ❖ When pressed with the MODE Button, toggles the display from % motor speed to input signal value.

- **MODE** Button -

- ❖ Used to select one of four operating modes.

Mode 1 - Manual Adjustment (external input disabled)

Mode 2 - 4-20mA input

Mode 3 - 0-10VDC input

Mode 4 - Frequency (Hz) input

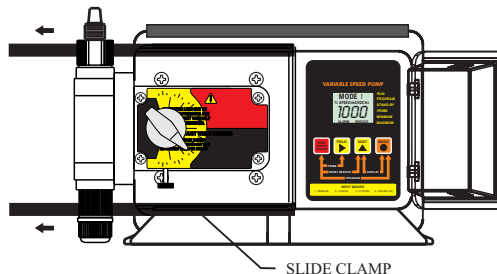
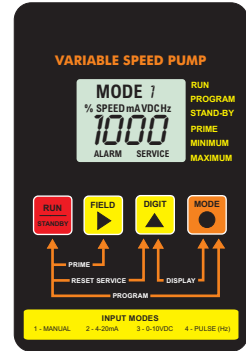

C-1100V

6.2 How to adjust the output- manual stroke adjustment

The Pump flow rate can be adjusted within a range of 5% -100% of maximum output (20:1 turndown ration) by means of a mechanical, cam type mechanism. The mechanism adjusts the pump's stroke length to an infinite number of settings within the flow range.

- Ø **Note:** The pump's output will reduce due to increased system pressure, increased suction lift, and increased fluid viscosity. The pump must be oversized to allow for these factors. Sizing the pump to allow adjustment within the midrange is preferred to maintain accuracy. Consult the factory for individual pump model output curve data.

To **adjust the pump's output:**

1. With the pump running, loosen the lock screw.
2. Turn the adjustment knob to the desired setting.
3. Re-tighten the lock screw.

6.3 OPERATING MODE 1 - Output adjusted manually -

In this mode, the pump's motor speed is adjusted manually using the front panel touch pad. The motor speed can be adjusted from 5-100%. To adjust the speed:

- ❖ **Set the pump for mode 1.** Press the MODE button until **MODE 1** is shown on the LCD display. The **%SPEED** icon will light. The large **3-DIGIT LCD** will indicate the currently programmed percentage of speed.
 - ❖ **Enter the programming mode.** At the same time, press the RUN/STANDBY button and the MODE button. A blinking **ARROW** will point to the word **PROGRAM**, indicating the program mode has been activated.
 - ❖ Press the FIELD button to select the digit to program. The digit will blink when selected.
 - ❖ Press the DIGIT button to change the selected digit.
 - ❖ Repeat until all digits are programmed.
 - ❖ To exit the programming mode, press the RUN/STANDBY button and the MODE button at the same time. The arrow next to the word **PROGRAM** will disappear.
- ✓ **NOTE:** If while in the program mode no buttons are pressed within 20 seconds, the circuitry will automatically return to the run mode, without saving changes.

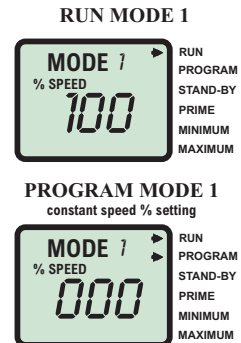

6.4 OPERATING MODE 2 - Output adjusted by 4-20 mA input signal -

In this mode, the pump's motor speed is adjusted automatically based on the value of the 4-20 mA input signal. Any motor speed can be assigned to either the minimum or maximum milliamp input values.

However, **the programmed minimum mA value must be less than the programmed maximum mA value.** The **ALARM** and **SERVICE** icons will blink if the programming is in error. To assign the minimum and maximum motor speed and the minimum and maximum mA input signal values:

- ❖ **Set the pump for mode 2.** Press the MODE button until **MODE 2** is shown on the LCD display. The **%SPEED** or **mA** icon will light depending on the current display setting. The large **3-DIGIT LCD** will indicate the current motor speed or the current mA input value.
- ❖ **Enter the programming mode.** At the same time, press the RUN/STANDBY and MODE buttons. A blinking **ARROW** will point to the word **PROGRAM** indicating the program mode is activated. A blinking **ARROW** will point to the word **MINIMUM** indicating the minimum value is ready to be programmed. The **% SPEED** icon will blink indicating the percentage of speed is ready to be programmed.
- ❖ **Enter the motor speed at the minimum mA input signal value.** Press the FIELD button to select the digit to program. The digit will blink when selected.
- ❖ Press the DIGIT button to change the selected digit.
- ❖ Repeat until all digits are programmed.
- ❖ Press the mode button. The **% SPEED** icon will stop blinking and the **mA** icon will blink indicating the minimum mA value is ready to be programmed. The currently programmed minimum value is shown on the **3-DIGIT LCD**.
- ❖ **Enter the minimum mA input signal value.** Note: this value must be less than the maximum mA input signal value. Press the FIELD button to select the digit to program. The digit will blink when selected.
- ❖ Press the DIGIT button to change the selected digit.
- ❖ Repeat until all digits are programmed.
- ❖ Press the mode button. The **Ma** icon will stop blinking and the **% SPEED** icon will blink. The **ARROW** next to the word **MAXIMUM** will blink indicating the

RUN MODE 2

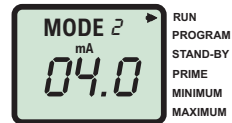

PROGRAM MODE 2
% speed at the minimum input

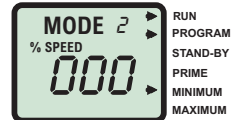

PROGRAM MODE 2
minimum input value

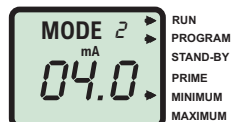

C-1100V

- ❖ maximum value is ready to be programmed. The currently programmed maximum motor speed value is shown on the **3-DIGIT LCD**.
- ❖ **Enter the motor speed at the maximum mA input signal value.** Press the FIELD button to select the digit to program. The digit will blink when selected.
- ❖ Press the DIGIT button to change the selected digit.
- ❖ Repeat until all digits are programmed.
- ❖ Press the mode button. The **% SPEED** icon will stop blinking and the **mA** icon will blink indicating the maximum mA value is ready to be programmed. The currently programmed maximum value is shown on the **3-DIGIT LCD**.
- ❖ **Enter the maximum mA input signal value.** Note: this value must be greater than the minimum mA input signal value. Press the FIELD button to select the digit to program. The digit will blink when selected..
- ❖ Press the DIGIT button to change the selected digit.
- ❖ Repeat until all digits are programmed.
- ❖ Press the mode button. Programming is complete.
- ❖ To exit the programming mode, press the RUN/STANDBY button and the MODE button at the same time. The PROGRAM arrow will disappear.

PROGRAM MODE 2
% speed at the maximum input

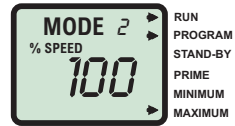

PROGRAM MODE 2
maximum input value

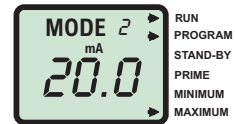

MODE 2 PROGRAMMING EXAMPLES

Example 1

4 mA = 0% OUTPUT
20 mA = 100% OUTPUT

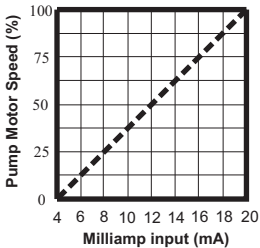

Example 2

4 mA = 100% OUTPUT
20 mA = 0% OUTPUT

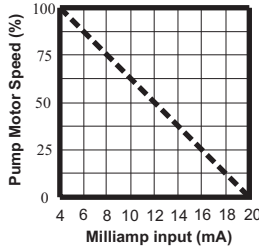

Example 4

4 mA = 20% OUTPUT
20 mA = 50% OUTPUT

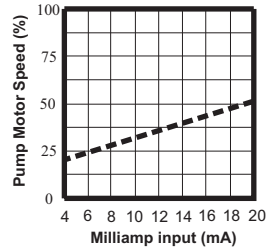

6.5 OPERATING MODE 3 - Output adjusted by 0-10VDC input signal -

In this mode, the pump's motor speed is adjusted automatically based on the value of the 0-10VDC input signal. Any motor speed can be assigned to either the minimum or maximum DC input signal values. However, **the programmed minimum VDC value must be less than the programmed maximum VDC value.** The **ALARM** and **SERVICE** icons will blink if the programming is in error. To assign the minimum and maximum motor speed and the minimum and maximum VDC input signal values:

- ❖ **Set the pump for mode 3.** Press the MODE button until **MODE 3** is shown on the LCD display. The **% SPEED** or **VDC** icon will light depending on the current display setting. The large **3-DIGIT LCD** will indicate the current motor speed or the VDC input value.
- ❖ **Enter the programming mode.** At the same time, press the RUN/STANDBY and MODE buttons. A blinking **ARROW** will point to the word **PROGRAM** indicating the program mode is activated. A blinking **ARROW** will point to the word **MINIMUM** indicating the minimum value is ready to be programmed. The **% SPEED** icon will blink indicating the percentage of speed is ready to be programmed.
- ❖ **Enter the motor speed at the minimum VDC input signal value.** Press the FIELD button to select the digit to program. The digit will blink when selected.
- ❖ Press the DIGIT button to change the selected digit.
- ❖ Repeat until all digits are programmed.
- ❖ Press the mode button. The **% SPEED** icon will stop blinking and the **VDC** icon will blink indicating the minimum VDC value is ready to be programmed. The currently programmed minimum value is shown on the **3-DIGIT LCD**.
- ❖ **Enter the minimum VDC input signal value.** Note: this value must be less than the maximum VDC input signal value. Press the FIELD button to select the digit to program. The digit will blink when selected.
- ❖ Press the DIGIT button to change the selected digit.
- ❖ Repeat until all digits are programmed.
- ❖ Press the mode button. The **VDC** icon will stop blinking and the **% SPEED** icon will blink. The **ARROW** next to the word **MAXIMUM** will blink

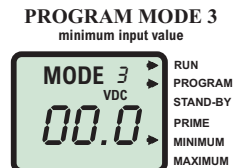
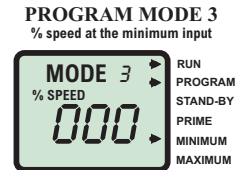
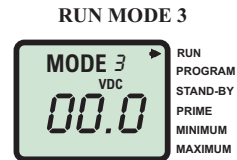

C-1100V

indicating the maximum value is ready to be programmed. The currently programmed maximum motor speed value is shown on the **3-DIGIT LCD**.

- ❖ **Enter the motor speed at the maximum VDC input signal value.** Press the FIELD button to select the digit to program. The digit will blink when selected.
- ❖ Press the DIGIT button to change the selected digit.
- ❖ Repeat until all digits are programmed.
- ❖ Press the mode button. The **% SPEED** icon will stop blinking and the **VDC** icon will blink indicating the maximum VDC value is ready to be programmed. The currently programmed maximum value is shown on the **3-DIGIT LCD**.
- ❖ **Enter the maximum VDC input signal value.** Note: this value must be greater than the minimum VDC input signal value. Press the FIELD button to select the digit to program. The digit will blink when selected.
- ❖ Press the DIGIT button to change the selected digit.
- ❖ Repeat until all digits are programmed.
- ❖ Press the mode button. Programming is complete.
- ❖ To exit the programming mode, press the RUN/STANDBY button and the MODE button at the same time. The **PROGRAM** arrow will disappear.

PROGRAM MODE 3
% speed at the maximum input

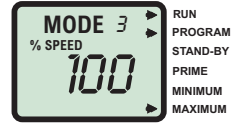

PROGRAM MODE 3
maximum input value

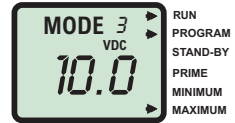

6.6 OPERATING MODE 4 - Output adjusted by frequency (Hz) input signal -

In this mode, the pump's motor speed is adjusted automatically based on the frequency (Hz) of the input signal. Any motor speed can be assigned to either the minimum or maximum Hz input signals. However, **the programmed minimum Hz value must be less than the programmed maximum Hz value.** The **ALARM** and **SERVICE** icons will blink if the programming is in error. To assign the minimum and maximum motor speed and the minimum and maximum Hz input signal values:

- ❖ ***Set the pump for mode 4.*** Press the MODE button until **MODE 4** is shown on the LCD display. The **% SPEED** or **Hz** icon will light depending on the current display setting. The large **3-DIGIT LCD** will indicate the current motor speed or the Hz input value.
- ❖ ***Enter the programming mode.*** At the same time, press the RUN/STANDBY and MODE buttons. A blinking **ARROW** will point to the word **PROGRAM** indicating the program mode is activated. A blinking **ARROW** will point to the word **MINIMUM** indicating the minimum value is ready to be programmed. The **% SPEED** icon will blink indicating the percentage of speed is ready to be programmed.
- ❖ ***Enter the motor speed at the minimum Hz input signal value.*** Press the FIELD button to select the digit to program. The digit will blink when selected.
- ❖ Press the DIGIT button to change the selected digit.
- ❖ Repeat until all digits are programmed.
- ❖ Press the mode button. The **% SPEED** icon will stop blinking and the **Hz** icon will blink indicating the minimum Hz value is ready to be programmed. The currently programmed minimum value is shown on the **3-DIGIT LCD**.
- ❖ ***Enter the minimum Hz input signal value (to the nearest 10 Hz).*** Note: this value must be less than the maximum Hz input signal value. Press the FIELD button to select the digit to program. The digit will blink when selected.
- ❖ Press the DIGIT button to change the selected digit.
- ❖ Repeat until all digits are programmed.
- ❖ Press the mode button. The **Hz** icon will stop blinking and the **% SPEED** icon will blink. The **ARROW** next to the word **MAXIMUM** will blink indicating the

RUN MODE 4

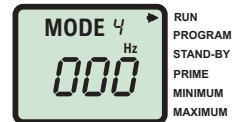

PROGRAM MODE 4 % speed at the minimum input

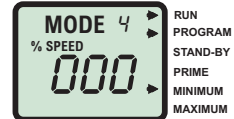

PROGRAM MODE 4 minimum input value

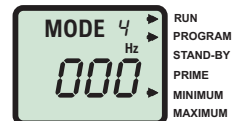

C-1100V

maximum value is ready to be programmed. The Currently programmed maximum motor speed value is shown on the **3-DIGIT LCD**.

- ❖ **Enter the motor speed at the maximum VDC input signal value.** Press the FIELD button to select the digit to program. The digit will blink when selected.
- ❖ Press the DIGIT button to change the selected digit.
- ❖ Repeat until all digits are programmed.
- ❖ Press the mode button. The % **SPEED** icon will stop blinking and the **Hz** icon will blink indicating the maximum Hz value is ready to be programmed. The currently programmed maximum value is shown on the **3-DIGIT LCD**.
- ❖ **Enter the maximum Hz input signal value (to the nearest 10 Hz).** Note: this value must be greater than the minimum Hz input signal value. Press the FIELD button to select the digit to program. The digit will blink when selected.
- ❖ Press the DIGIT button to change the selected digit.
- ❖ Repeat until all digits are programmed.
- ❖ Press the mode button. Programming is complete.
- ❖ To exit the programming mode, press the RUN/STANDBY button and the MODE button at the same time. The **PROGRAM** arrow will disappear.

PROGRAM MODE 4
% speed at the maximum input

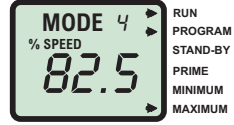

PROGRAM MODE 4
minimum input value

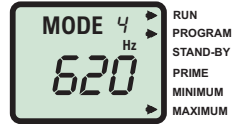

MODE 4 PROGRAMMING EXAMPLES

Example 1

0 Hz = 0% OUTPUT
1000 Hz = 100% OUTPUT

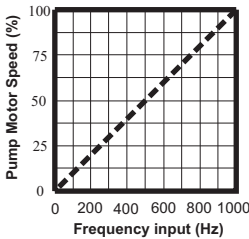

Example 2

0 Hz = 100% OUTPUT
1000 Hz = 0% OUTPUT

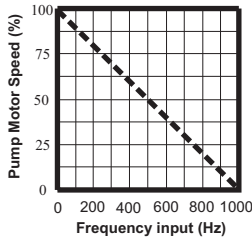

Example 3

0 Hz = 10% OUTPUT
270 Hz = 75% OUTPUT

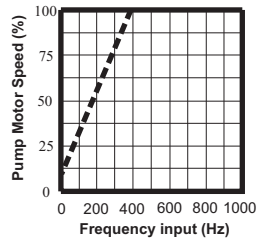

6.7 Measuring the Pump's Output - Volumetric Test.

This volumetric test will take into account individual installation factors such as line pressure, fluid viscosity, suction lift, etc. This test is the most accurate for measuring the injector's output in an individual installation.

1. Be sure the Injection Fitting and Footvalve/Strainer is clean and working properly.
2. Fill a large graduated cylinder with the solution to be injected.
3. With the pump installed under normal operating conditions, place the suction tubing with the Footvalve/Strainer installed in the graduated cylinder.
4. Run the pump until all air is removed from the suction line and the solution enters the discharge tubing. If the pump does not easily prime, remove the discharge tubing from injection fitting until the pump primes. Re-connect the discharge tubing to the injection fitting.
5. Remove the suction tubing from the graduated cylinder and refill the graduated cylinder if necessary. Note the amount of solution in the graduated cylinder.
6. Place suction tubing with the Footvalve/Strainer installed back into the graduated cylinder.
7. Run the injector for a measured amount of time. A longer testing time will produce more accurate results.
8. Remove the suction tubing from the graduated cylinder. Measure the amount of chemical injected.

6.8 FVS - Flow Verification System - (sensor sold separately) The C-1100V is equipped with a *Flow Verification System* which is designed to stop the pump and provide a contact closure output in the event the sensor does not detect chemical during pump operation. This could indicate a clogged injection fitting, empty chemical solution tank, loose tubing connection, etc.

To allow the pump to clear any gasses that may have accumulated during stopper operation (such as with chlorine), an alarm delay time value from 1-256 seconds must be programmed (An alarm delay value of 000 seconds disables the FVS system). Press the FIELD and DIGIT buttons at the same time to enter the delay value. The pump will stop, and the alarm mode activated, if no pulses are received by the pump and the alarm delay time period has ended. Press the STAND-BY button twice to clear the alarm and restart the pump. The Flow Verification Sensor is sold as an optional accessory.

C-1100V

Confirm the FVS flow range - The Flow Verification Sensor (FVS) will only function within its operating range. Sensor model FV-100-6V has an operating range of 30-300 ml/min (1-10 oz/min). If the pump's output is less than 30 ml/min (0.5 ml/sec), the sensor will not detect chemical and a signal will not be sent to the pump.

SENSOR MODEL NUMBER	OPERATING FLOW RANGE (ml/min)
FV-100-6V	30-300
FV-200-6V	100-1000
FV-300-6V	200-2000
FV-400-6V	300-3000
FV-500-6V	500-5000
FV-600-6V	700-7000

Install the FVS Flow Sensor - The Flow Verification Sensor (FVS) should be installed on the outlet (discharge) side of the pump head valve. The sensor includes a PVC tubing insert, located inside the sensor's female thread connection, that is designed to seal the sensor onto the pump head inlet adapter. Thread the sensor onto the pump head until the tubing insert is snug against the pump head inlet fitting - do not over-tighten. Connect the red/white, black, and white wires from the sensor to the red, black, and yellow wires located in the pump's junction box. See page 7.

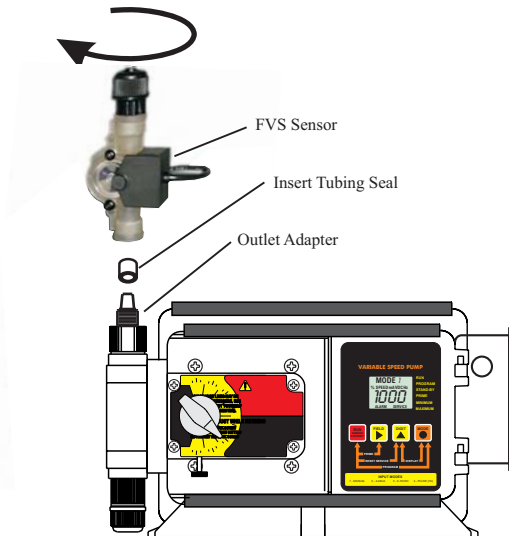

Contact Closure Alarm Output - A contact closure output (relay) is provided with the FVS system. The relay can be configured for normally open (factory default) or normally closed operation by properly positioning the connector plug on the circuit board (see page 7).

7.0 How to Maintain the Pump

CAUTION: Proper eye and skin protection must be worn when installing and servicing the pump.

7.1 Routine Inspection and Maintenance

The pump requires very little maintenance. However, the pump and all accessories should be checked regularly. This is especially important when pumping chemicals. Inspect all components for signs of leaking, swelling, cracking, discoloration or corrosion. Replace worn or damaged components immediately.

Cracking, crazing, discoloration and the like during the first week of operation are signs of severe chemical attack. If this occurs, immediately remove the chemical from the pump. Determine which parts are being attacked and replace them with parts that have been manufactured using more suitable materials. The manufacturer does not assume responsibility for damage to the pump that has been caused by chemical attack.

7.2 How to Clean the Pump

The pump will require occasional cleaning, especially the Injection fitting, the Footvalve/Strainer, and the pump head valves. The frequency will depend on the type and severity of service.

- ☑ Inspect and replace the pumphead valves as required.
- ☑ When changing the diaphragm, the pump head chamber and pump head cover should be wiped free of any dirt and debris.
- ☑ Periodically clean the injection/check valve assembly, especially when injecting fluids that calcify such as sodium hypochlorite. These lime deposits and other build ups can clog the fitting, increase the back pressure and interfere with the check valve operation. See page 8.
- ☑ Periodically clean the suction strainer. See page 8.
- ☑ Periodically inspect the air vents located under the motor housing and in the back on the rear housing cover. Clean if necessary.

7.3 500 Hour Service Warning Timer

The pump is equipped with a service warning timer. After approximately 500 hours of accumulated running time, the **SERVICE** icon will light. This is a reminder that the pump should be inspected and maintenance performed if necessary.

C-1100V

PUMP HEAD AND VALVE EXPLODED VIEW

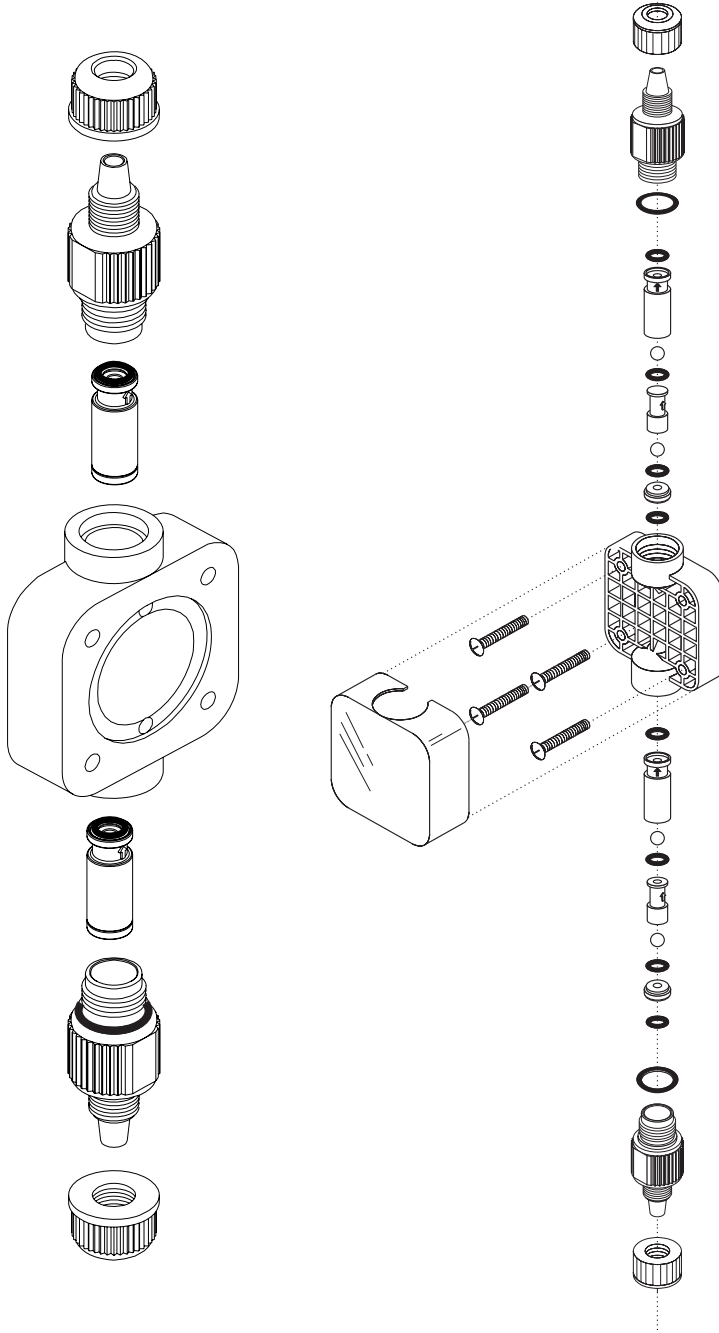

Replacement Parts Drawing

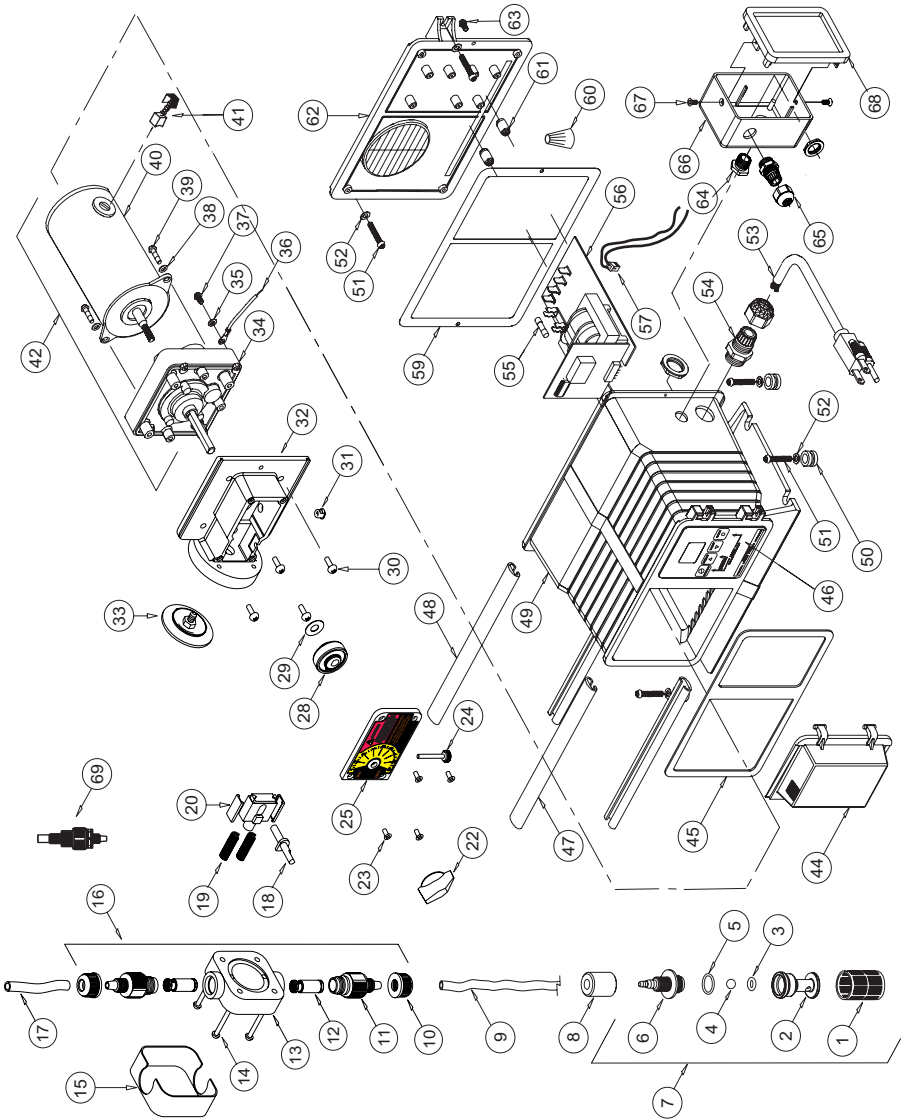

C-1100V**PARTS LIST**

Item	Part No	Description	Qty	Item	Part No	Description	Qty
1	C-345S	Screen, FootValve, P.P.	1		C-618N-45	Gearbox, 45 RPM	1
2	90002-214	Body, FootValve, PVDF	1		C-618N-60	Gearbox, 60 RPM	1
3	2-108A	O-ring, FootValve, Atlas	1		C-618N-125	Gearbox, 125 RPM	1
	2-108E	O-ring, FootValve, E.P.	1		C-618N-250	Gearbox, 250 RPM	1
4	C-385C	Ball, FootValve, Ceramic	1	35	90011-078	Washer, Ground, #8 Star	1
5	90003-014	O-ring, FootValve, Viton	1	36	90010-222	Lead Wire, ground, Green	1
	90003-015	O-ring, FootValve, E.P.	1	37	90011-024	Screw 8-32 x .25 SL ST	1
6	90002-215	Adapter, FootValve, PVDF	1	38	90011-074	Washer, #8 split-lock	2
7	C-340E	FootValve, C-340E, EP	1	39	90011-023	Screw, motor, 8-32 x .50	2
	C-340A	FootValve, C-340V, Vit/Aflas1	1	40	90010-244	Motor, 24V DC	1
8	C-346	Ceramic weight, C-346	1	41	C-1814N-4	Brush kit, (2 pc.) 24V DC	1
9	C-334-6	Tubing Suction 3/8 x 5 FT	1	42	70002-255	G/motor, 14 Rpm, 24VDC	1
10	C-330-6	Tube Nut, .37T, P.P.	2		70002-256	G/motor, 30 Rpm, 24VDC	1
11	C-560-6V	Adapter S/A .37T Viton	2		70002-257	G/motor, 45 Rpm, 24VDC	1
	C-560-6E	Adapter S/A .37T EP	2		70002-258	G/motor, 60 Rpm, 24VDC	1
	C-560-6S	Adapter S/A .37T Sil	2		70002-259	G/motor, 125 Rpm, 24VDC	1
12	K-568-4A	Cartridge Valve S/A	2		70002-260	G/motor, 250 Rpm, 24VDC	1
13	C-535	P/Head Noir Molded, P.P.	1	44	90002-191	Door, Controls Cover	1
14	C-504HD	Screw 10-32 x 1.25	4	45	90006-579	Gasket, Front, Neoprene	1
15	C-535FC	Cover P/Head,	1	46	90012-245	Label Timer w/ Ext. Input	1
16	C-535A6-6	Kit P/Head, 37T Vit/Afl, P-P	1	47	76000-999	Slide Clamp, Front	2
	C-535A6-6E	Kit P/Head, 37T E.P. P-P	1	48	76001-000	Slide Clamp, Rear	2
17	C-334-6-10	Tubing DI/Charge, 3/8 x 10'	1	49	76001-253	Enclosure, w/ Ext. Input	1
18	C-1505N	Offset Cam #1 .125"	1	50	90003-559	Mounting Feet, Rubber	4
	R-1505N	Offset Cam #2 .055"	1	51	90011-091	Screw, #10 X 1.0" Phil	6
	C-1505N-3	Offset Cam #3 .187"	1	52	90011-094	Washer, #10 Stainless	6
	C-1505N-4	Offset Cam #4 .100"	1	53	71000-175	Power Cord, 220v50hz,	1
19	C-1514N	Return Spring	2		71000-177	Power Cord, 230v60hz,	1
20	C-1513N	Stirrup with slide bearings	1	54	70000-589	Connector Liq-tite .375	1
22	C-1502	Dial Knob	1	55	90010-235	Fuse, 1A, 250VAC	1
23	90011-168	Screw #6 x .62 PH oval 'A'	4	56	A-023N-V-115	Circuit board, 115V	1
24	C-1519N	Thumb Screw 6-32 x 1.125	1		A-023N-V-230	Circuit board, 220V/230V	1
25	71000-363	Cover Cam S/A C-1100	1	57	90010-246	Wire set w/plug, alarm relay	1
28	C-1507A	Drive Cam S/A #1 .125"	1	59	90006-580	Gasket, Back Plate	1
	R-1507A	Drive Cam S/A #2 .055"	1	60	90010-036	Wire Nut, Blue	2
	C-1507-3A	Drive Cam S/A #3 .187"	1	62	71000-489	Enclosure Back w/Gasket	1
	C-1507-4A	Drive Cam S/A #4 .100"	1	63	90011-044	Screw 6-32 x .37	2
29	A-031	Spacer, Rotor	1	64	90007-515	Bushing, J-Box, Alum.	1
30	C-624N	Screw 10-32 x .50 PHL	4	65	90008-199	Connector Liq-tite .187	1
31	90008-138	Plug .312 Hole Black	1	66	76001-254	Junction Box, Input, Valox	1
32	76001-183	Motor Mount, Large Dia	1	67	90011-129	Screw, 6-32 X .25 SS	2
33	C-406VT-15N	Diaphragm 2.0 Vit/TFE	1	68	71000-133	Cover, J-Box w/Gasket,	1
	C-406T-15N	Diaphragm 2.0 EP/TFE	1	69	A-014N-6A	Inj. Valve .37od, 1/2 lb spring	1
34	C-618N-14	Gearbox, 14 RPM	1		C-395N-6A	Inj. Valve .37od, 6lb spring	1
	C-618N-30	Gearbox, 30 RPM	1				