

— MODEL — **CRD**

Pressure Reducing Control



DESCRIPTION

The Cla-Val Model CRD Pressure Reducing Control automatically reduces a higher inlet pressure to a lower outlet pressure. It is a direct acting, spring loaded, diaphragm type control that operates hydraulically or pneumatically. It may be used as a self-contained valve or as a pilot control for a Cla-Val main valve. It will hold a constant downstream pressure within very close pressure limits.

OPERATION

The CRD Pressure Reducing Control is normally held open by the force of the compression spring above the diaphragm; and delivery pressure acts on the underside of the diaphragm. Flow through the valve responds to changes in downstream demand to maintain a pressure.

INSTALLATION

The CRD Pressure Reducing Control may be installed in any position. There is one inlet port and two outlets, for either straight or angle installation. The second outlet port can be used for a gage connection. A flow arrow is marked on the body casting.

ADJUSTMENT PROCEDURE

The CRD Pressure Reducing Control can be adjusted to provide a delivery pressure range as specified on the nameplate.

Pressure adjustment is made by turning the adjustment screw to vary the spring pressure on the diaphragm. The greater the compression on the spring the higher the pressure setting.

1. Turn the adjustment screw in (clockwise) to increase delivery pressure.
2. Turn the adjustment screw out (counter-clockwise) to decrease the delivery pressure.
3. When pressure adjustment is completed tighten jam nut on adjusting screw and replace protective cap.
4. When this control is used, as a pilot control on a Cla-Val main valve, the adjustment should be made under flowing conditions. The flow rate is not critical, but generally should be somewhat lower than normal in order to provide an inlet pressure several psi higher than the desired setting

The approximate minimum flow rates given in the table are for the main valve on which the CRD is installed.

Valve Size	1 1/4" -3"	4"-8"	10"-16"
Minimum Flow GPM	15-30	50-200	300-650

SYMPTOM	PROBABLE CAUSE	REMEDY
Fails to open when delivery pressure lowers	No spring compression	Tighten adjusting screw
	Damaged spring	Disassemble and replace
	Spring guide (8) is not in place	Assemble properly
	Yoke dragging on inlet nozzle	Disassemble and reassemble properly (refer to Reassembly)
Fails to close when delivery pressure rises	Spring compressed solid	Back off adjusting screw
	Mechanical obstruction	Disassemble and reassemble properly (refer to Reassembly)
	Worn disc	Disassemble remove and replace disc retainer assembly
	Yoke dragging on inlet nozzle	Disassemble and reassemble properly (refer to Reassembly)
Leakage from cover vent hole	Damaged diaphragm	Disassemble and replace
	Loose diaphragm nut	Remove cover and tighten nut

MAINTENANCE

Disassembly

To disassemble follow the sequence of the item numbers assigned to parts in the sectional illustration.

Reassembly

Reassembly is the reverse of disassembly. Caution must be taken to avoid having the yoke (17) drag on the inlet nozzle of the body (18). Follow this procedure:

1. Place yoke (17) in body and screw the disc retainer assembly (16) until it bottoms.
2. Install gasket (14) and spring (19) for 2-30 and 2-6.5 psi range onto plug (13) and fasten into body. Disc retainer must enter guide hole in plug as it is assembled. Screw the plug in by hand. Use wrench to tighten only.
3. Place diaphragm (12) diaphragm washer (11) and Belleville washer (20) on yoke. Screw on hex nut (10).
4. Hold the diaphragm so that the screw holes in the diaphragm and body align. Tighten diaphragm nut with a wrench. At the final tightening release the diaphragm and permit it to rotate 5° to 10°. The diaphragm holes should now be properly aligned with the body holes.

To check for proper alignment proceed as follows:

Rotate diaphragm clockwise and counterclockwise as far as possible. Diaphragm screw holes should rotate equal distance on either side of body screw holes $\pm 1/8"$.

Repeat assembly procedure until diaphragm and yoke are properly aligned. There must be no contact between yoke and body nozzle during its normal movement. To simulate this movement hold body and diaphragm holes aligned. Move yoke to open and closed positions. There must be no evidence of contact or dragging.

5. Install spring (9) with spring guide (8).
6. Install cover (5), adjusting screw (2) and nut (3), then cap (1).



CRD

Pressure Reducing Control

(Bronze Body with 303SS Trim)

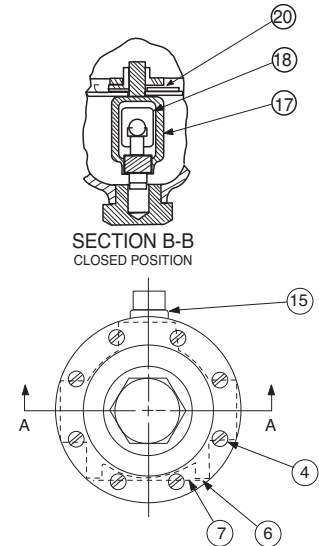
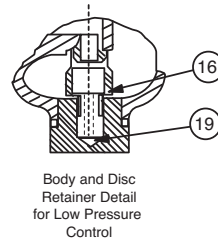
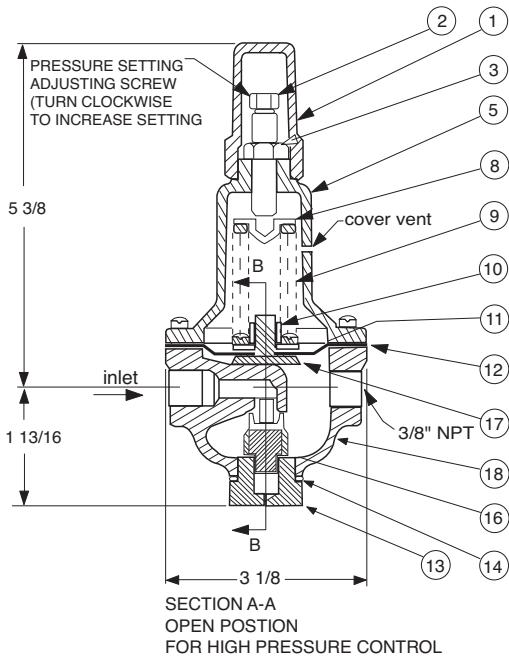

Size (inch)	Stock Number	Adjustment Range	
		psi	Ft of Water
3/8	7194307A	2 - 6.5	4.5 - 15
3/8	7194308J	2 - 30	4.5 - 69
3/8	7194303K	15 - 75	35 - 173
3/8	7194311C	20 - 105	46 - 242
3/8	7194304H	30 - 300	69 - 692
Factory Set Pressure			PSI per Turn*
	2 - 6.5 set @ 3.5 psi		.61
	2 - 30 set @ 10 psi		3.0
	15 - 75 set @ 20 psi		9.0
	20 - 105 set @ 60 psi		12.0
	30 - 300 set @ 60 psi		27.0

*Approximate-Final Adjustment should be with a pressure gauge and with flow.

Item	Description	Material	Part Number	List Price
1	Cap	PL	67628J	
2	Adjusting Screw	BRS	7188201D	
3	Jam Nut (3/8-16)	SS	6780106J	
4*	Machine Screw (Fil.Hd.) 8 Req'd	303	6757821B	
5	Cover	BRS	C2544K	
6	Nameplate Screw	SS	67999D	
7	Nameplate	BRS	C0022001G	
8	Spring Guide	302	71881H	
	Spring Guide (20 - 105 psi)	303	205620F	
9	Spring (15-75 psi)	CHR/VAN	71884B	
	Spring (2 - 6.5 psi)	SS	82575C	
	Spring (2 - 30 psi)	SS	81594E	
	Spring (20 - 105 psi)	316	20632101E	
	Spring (30 - 300 psi)	CHR/VAN	71885J	
10	Hex Nut	303	71883D	
11	Diaphragm Washer	302	71891G	
12*	Diaphragm	NBR	C6936D	
13	Plug, Body	BRS	V5653A	
14*	Gasket	Fiber	40174F	
15	Plug	BRS	6766003F	
16*	Disc Retainer Assy. (2 - 30 psi)	SS/Rub	C8348K	
	Disc Retainer Assy. (15 - 75 psi)	SS/Rub	37133G	
	Disc Retainer Assy. (20 - 105 psi)	SS/Rub	37133G	
	Disc Retainer Assy. (30 - 300 psi)	SS/Rub	37133G	
17	Yoke	VBZ	V6951H	
18	Body & 1/4" Seat Assy	BR/SS	8339702G	
19*	Bucking Spring (2 - 6.5 psi)(2 - 30psi)	302	V0558G	
20	Belleville Washer	STL	7055007E	
*	Repair Kit (No Bucking Spring)	Buna®-N	9170003K	
*	Repair Kit (with Bucking Spring)	Buna®-N	9170002B	

*SUGGESTED REPAIR PARTS

When ordering parts specify:

- All nameplate data
- Item Description
- Item number