



Two-Door Check Valve

Series 582W Series 582 Series 582G



2 1/2" - 16"
65 - 400mm

2 1/2" - 12"
65 - 300mm



Series 582W

Series 582

Series 582G

SPECIFICATIONS

The two-door wafer check valve shall be compact wafer design, to fit between flanges or grooved ends. The check valve doors shall be spring-loaded closed, by means of one or more stainless steel torsion springs. Flow shall cause the doors to open and upon pump shut down, the torsion spring shall shut the doors, before reverse flow, for anti-slam closure.

Seating shall be resilient Buna-N®, watertight and molded to the body. Valves 6" and larger shall be supplied with an eye bolt for lifting. The valve shall be a Cla-Val Series 582W 2"-12" having alignment wings for mounting between ANSI 125, ISO PN10 or PN16 flanges or Series 582 (14"-60") for mounting between ANSI 125 or 150 flanges or Series 582G (2"-12") with grooved ends for mounting between groove end piping.

All materials of construction shall conform to ASTM specifications as follows:

- New - Lower Head Loss Design
- New - Alignment Wings for ANSI 125, ISO PN10 & PN16 Mounting
- High Speed Anti-Slam Closure
- Stabilizer Spheres Prevent Vibration Wear
- Factory Mutual Approved / UL Listed
- Plain Ends or Grooved Ends

All Cla-Val Series 582 Two-Door Check Valves utilize a torsion springs that very quickly shut the valve, before flow reversal. To minimize Slam / Water Hammer typically experienced with conventional swing check valves. Basically Two Door design valves, halves the travel distance from open valve to shut-off vs swing check valves and is the reason for the Anti-slam / Minimum Water Hammer feature. With extremely short laying lengths series 582W and Series 582 are space savings & an economical solution. The Series 582G with grooved ends provides for ease of installation and removal from pipelines. Although lighter in weight than conventional swing check valves, Cla-Val Two-Door Wafer Check Valves are designed for heavy-duty applications. For ease of installation, valves 6" and larger are supplied with lifting eye bolts. All materials conform to ASTM specifications, ensuring long lasting reliable performance.

Valve Body:

Series 582W & 582G 2" - 12"

Ductile Iron ASTM A536

Series 582 14" - 16"

Cast Iron ASTM A126, Class B

Doors:

2" - 12" Bronze ASTM B584

14" - 60" Aluminum Bronze ASTM B148

Sealing Element:

Buna-N®

Torsion Spring:

316

Stainless Steel

Hinge:

316

Stainless Steel

Stop:

316

Stainless Steel

Sizes:

2" to 60"

Series 582 Pressure Loss Curve

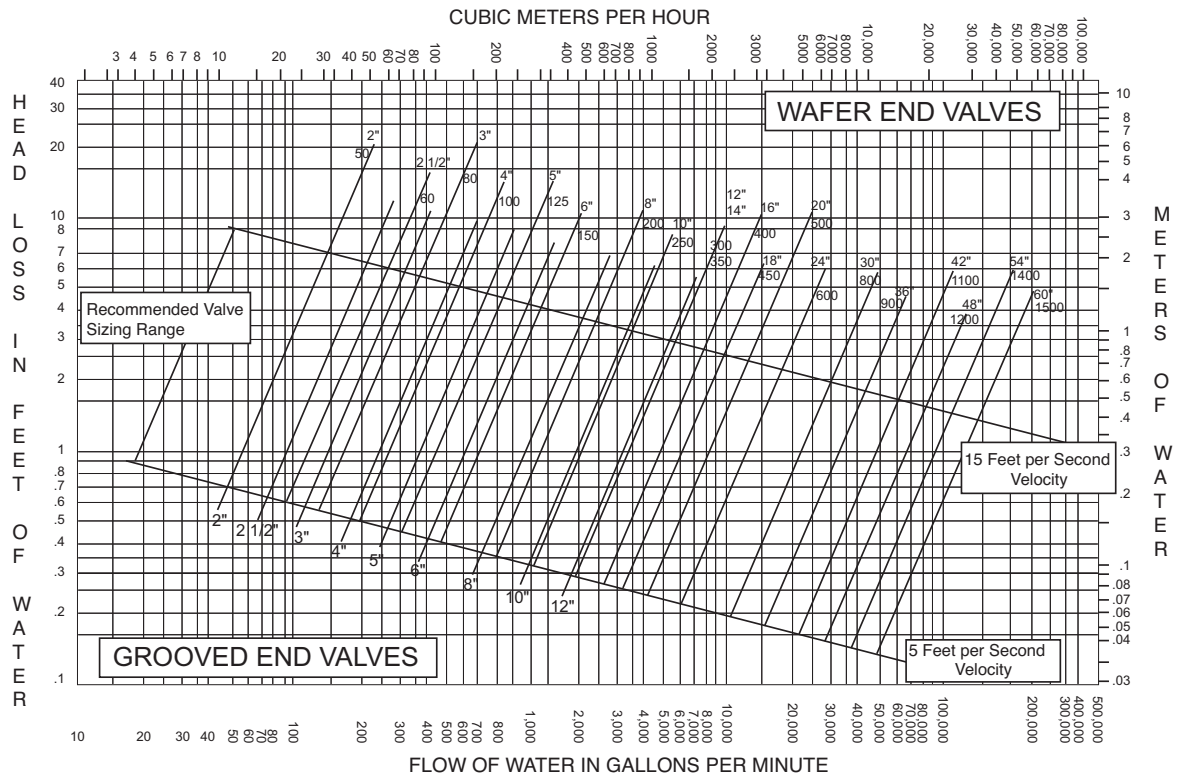

Series 582 Two-Door Wafer Check Valve



APPROVED
2 1/2" - 16"
65 - 400 mm

2 1/2" - 12"
65 - 300 mm

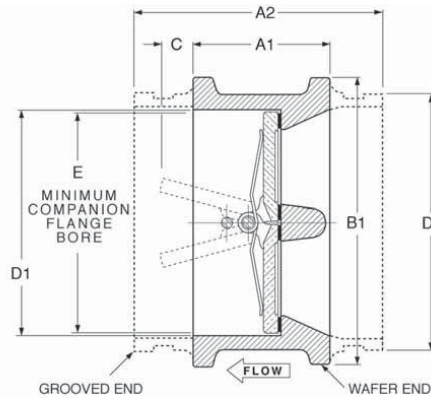
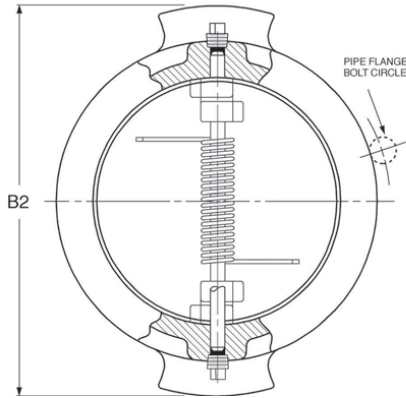

Dimensions (In Inches)

Cla-Val Series 582 Two-Door Wafer Check Valve ANSI CLASS 125										Wafer	Grooved
Size	A	A2	B1	B2	C	D1	D2	E		Wt Lbs.	Wt Lbs.
2	2 1/8	4 21/32	4 1/8	5 1/8	3/16	2 9/16	2 3/8	1 15/16		4	4
2 1/2	2 3/8	4 29/32	4 7/8	6	5/16	3 1/16	2 7/8	2 5/16		5	5
3	2 5/8	5 5/16	5 3/8	5 5/8	1/2	3 11/16	3 1/2	2 7/8		7	8
4	2 5/8	5 3/8	6 7/8	7 3/4	1	4 5/8	4 1/2	3 7/8		9	9
5	3 1/4	5 23/32	7 3/4	7 9/16	1 1/8	5 11/16	5 9/16	4 13/16		13	13
6	3 3/4	6	8 3/4	8 5/8	1 1/4	6 3/4	6 5/8	5 3/4		19	18
8	5	6 23/32	11	12 1/4	1 5/16	8 3/4	8 5/8	7 5/8		38	30
10	5 1/2	7 25/32	13 3/8	13 3/4	2 1/2	10 7/8	10 3/4	9 9/16		65	56
12	7 1/8	8 3/16	16 1/8	17 3/8	2 3/8	12 7/8	12 3/4	11 3/8		94	81
14	7 1/4	N/A	17 3/4	N/A	3 1/4	14 3/4	N/A	12 1/2		187	N/A
16	7 1/2	N/A	20 1/4	N/A	4 1/2	16 3/8	N/A	15		270	N/A
18	8	N/A	21 5/8	N/A	5 3/8	18 3/8	N/A	17		330	N/A
20	8 3/8	N/A	23 7/8	N/A	6 3/8	20 1/4	N/A	19		424	N/A
24	8 3/4	N/A	28 1/4	N/A	8 1/2	24 1/4	N/A	23		589	N/A
30	12	N/A	34 3/4	N/A	9 1/2	30	N/A	28 1/2		1,112	N/A
36	14 1/2	N/A	41 1/4	N/A	12	36	N/A	34 1/2		1,864	N/A
42	17	N/A	48	N/A	13 3/4	42	N/A	40 1/2		2,889	N/A
48*	20 5/8	N/A	N/A	59 1/2	17	48	N/A	46 1/2		5,525	N/A
54*	21 1/4	N/A	N/A	66 1/4	20	54	N/A	52 1/2		7,000	N/A
60*	26	N/A	N/A	73	19	60	N/A	58 1/2		10,100	N/A

Pressure - Temperature Rating

Temp °F.	Maximum Non-Shock Pressure PSI (Ductile Iron Body)
150°F	250
200°F	235
250°F	220
Hydrostatic Test Pressure	500

INSTALLATION

Install the Cla-Val Series 582 Two-Door Wafer Check Valve between standard flanges in the horizontal or in the vertical, flow up, position.

Dimensions (mm)

Cla-Val Series 582 Two-Door Wafer Check Valve ANSI CLASS 125										Wafer	Grooved
Size	A	A2	B1	B2	C	D1	D2	E		Wt Lbs.	Wt Lbs.
2	54	118.3	104.8	130.2	4.8	65.1	60.9	49.2		1.8	1.8
2 1/2	60.3	124.6	123.8	152.4	7.9	77.8	73	58.7		2.3	2.3
3	66.7	134.9	136.5	136.5	12.7	93.7	88.9	73		3.2	3.6
4	66.7	136.5	174.6	196.8	25.4	117.5	114.3	98.4		4.1	4.1
5	82.6	145.2	196.8	192.1	28.6	144.5	141.3	122.2		5.9	5.9
6	95.3	152.4	222.2	219.1	31.8	171.4	168.3	146		8.6	8.2
8	127	170.6	279.4	311.3	33.3	222.2	219.1	193.7		17.2	13.6
10	139.7	197.6	339.7	349.2	63.5	276.2	273	242.9		29.5	25.4
12	181	208	409.6	441.3	60.3	327	323.7	288.9		42.6	36.7
14	184.1	N/A	450.8	N/A	82.6	365.1	N/A	317.5		84.8	N/A
16	190.5	N/A	514.3	N/A	114.3	415.9	N/A	381		122	N/A
18	203.2	N/A	549.3	N/A	136.5	466.7	N/A	431.8		150	N/A
20	212.7	N/A	606.4	N/A	161.9	514.3	N/A	482.6		192	N/A
24	222.2	N/A	717.5	N/A	215.9	615.9	N/A	584.2		268	N/A
30	304.8	N/A	882.6	N/A	241.3	768	N/A	723.9		504	N/A
36	368.3	N/A	1048	N/A	304.8	914.4	N/A	876.3		846	N/A
42	431.8	N/A	1219	N/A	349.2	1067	N/A	1029		1310	N/A
48*	523.9	N/A	N/A	1511	431.8	1219	N/A	1181		2506	N/A
54*	539.8	N/A	N/A	1683	508	1372	N/A	1336		3175	N/A
60*	660.4	N/A	N/A	1854	482.6	1524	N/A	1486		4580	N/A

*Threaded Flange Standard

NOTE:

For horizontal flow this valve MUST Be installed with disc hinge pin in the VERTICAL position for proper operation.